



Email: market@cnggrandmachinery.com

Cosmetic Cream Toothpaste Lotion Machine
Professional Manufacturer
乳化设备专业制造商



**WENZHOU GRAND MACHINERY
TECHNOLOGY CO.,LTD**

☎ 0086-577-6556 5288/5188

🌐 WWW.CNGRANDMACHINERY.COM

📍 NO.505, HONGJIN ROAD FEIYUN STREET,
RUIAN 325207,WENZHOU CITY,
ZHEJIANG PROVINCE,CHINA



EMULSIFYING SERIES

乳化搅拌系列

用途 Use

本设备适用于药膏、化妆品、牙膏、栓剂、洗液等膏、霜类产品的制作。

This equipment is suitable for emulsifying cream, ointment, toothpaste, lotion, shampoo, cosmetic product and so on.

FLOW CHART OF VACUUM EMULSIFYING MIXER 真空乳化机工艺流程

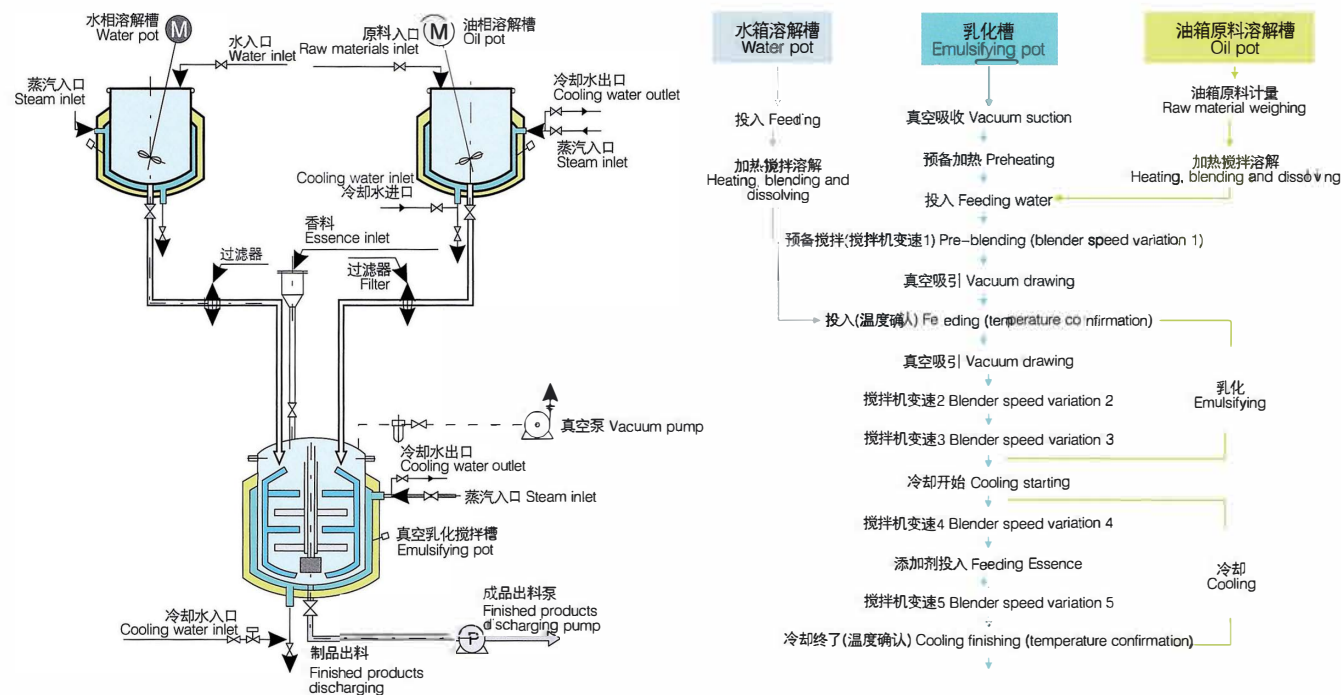

主要技术参数 Main Technical Parameters

型号 Model	容积 Volume	乳化电机功率 Emulsify motor	刮壁电机功率 Mixer power	长 Length	宽 width	高 height	全高 Max height		
CBZRJ-10	10L	1.1KW	0-3500rpm/min	0.37Kw	0-60r/m	1200	600	1300	1700
CBZRJ-20	20L	1.5KW	0-3500rpm/min	0.75Kw	0-60r/m	1500	800	1500	2050
CBZRJ-50	50L	3KW	0-3500rpm/min	0.75Kw	0-60r/m	2750	2100	1900	2600
CBZRJ-100	100L	3KW	0-3500rpm/min	1.5kw	0-60r/m	2800	2150	2100	2800
CBZRJ-200	200L	4KW	0-3500rpm/min	1.5kw	0-60r/m	2850	2200	2200	3100
CBZRJ-300	300L	5KW	0-3500rpm/min	2.2kw	0-60r/m	3000	2600	2500	3550
CBZRJ-500	500L	7.5KW	0-3500rpm/min	2.2kw	0-60r/m	3800	2800	2700	3950
CBZRJ-750	750L	11KW	0-3500rpm/min	3.7kw	0-60r/m	3900	3900	2900	4400
CBZRJ-1000	1000L	11KW	0-3500rpm/min	3.7kw	0-60r/m	3900	3400	3150	4550
CBZRJ-2000	2000L	22KW	0-3500rpm/min	7.5kw	0-60r/m	4850	4300	3600	

VACUUM EMULSIFYING MIXER (UP HOMOGENIZER) CBZRJ 上均质真空乳化机

CBZRJ型真空乳化机是集均质、乳化、混合、分散、抽气、加热、冷却等功能为一体的新型真空乳化设备。

CBZRJ vacuum emulsifying machine is a new type of vacuum emulsification equipment integrating homogenization, emulsification, mixing, dispersion, air extraction, heating, cooling and other functions.

对粘度在50,000cp以下的膏、霜类（或胶体）物料，在真空状态下进行均质、乳化、搅拌，可根据用户产品工艺需求，运用加热和冷却装置，自由选择所需工作温度、工作时间，配备物料温控系统，从而获得高品质的产品。

For paste, cream (or colloid) materials with a viscosity below 50,000cp, homogenization, emulsification, mixing are all in a vacuum state, and Machine applies heating and cooling devices to freely choose the required working temperature and time according to the users' product process requirements. Machine is equipped with material temperature control system, so as to achieve high-quality products.

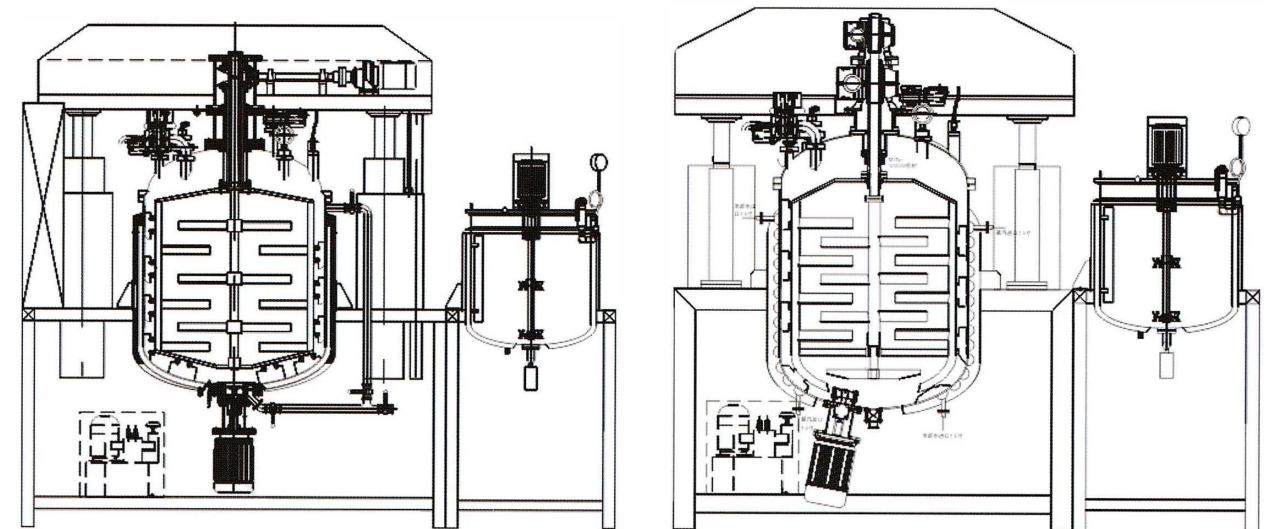

EMULSIFYING SERIES

| 乳化搅拌系列 |

VACUUM EMULSIFYING MIXER (BOTTOM HOMOGENIZER) CBZRJ 下均质真空乳化机

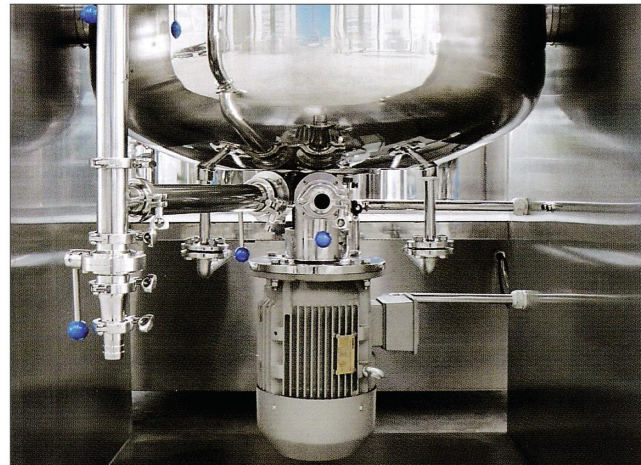
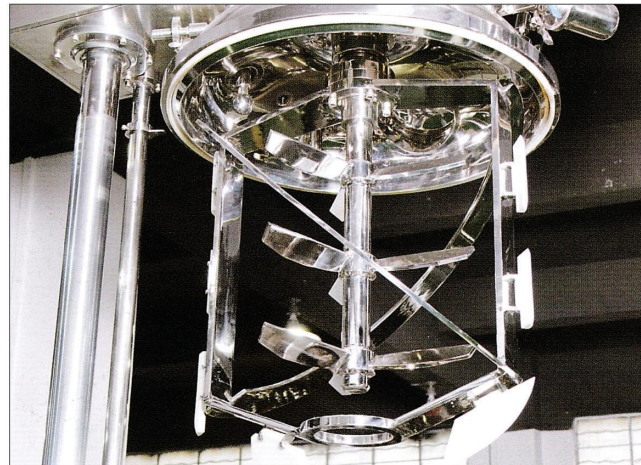

VACUUM EMULSIFYING MIXER (FIXED TYPE) CBZRJ 固定式真空乳化机

所有与物料相接触的部位均采用优质不锈钢及无毒、无害材料，保证制品的卫生质量。
All materials contact parts are made of high-quality stainless steel, non-toxic and harmless materials to ensure that the finished product hygiene quality.

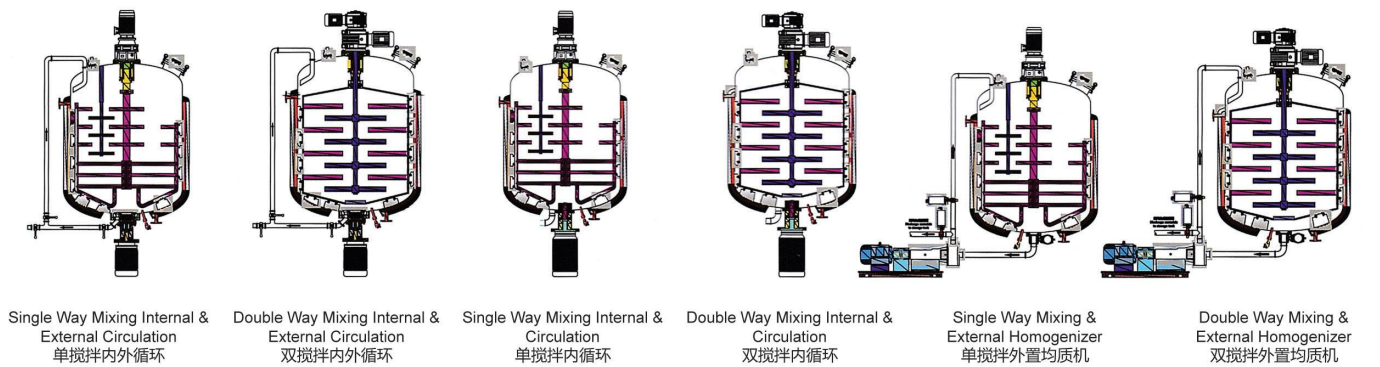

EMULSIFYING SERIES

| 乳化搅拌系列 |

VACUUM EMULSIFYING MIXER (UP HOMOGENIZER)
CBZRJ 上均质真空乳化机

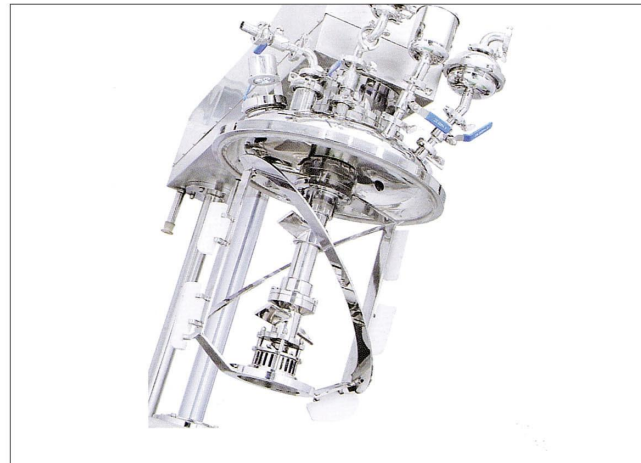

TOOTHPASTE MAKING MACHINE
YGJ 牙膏机

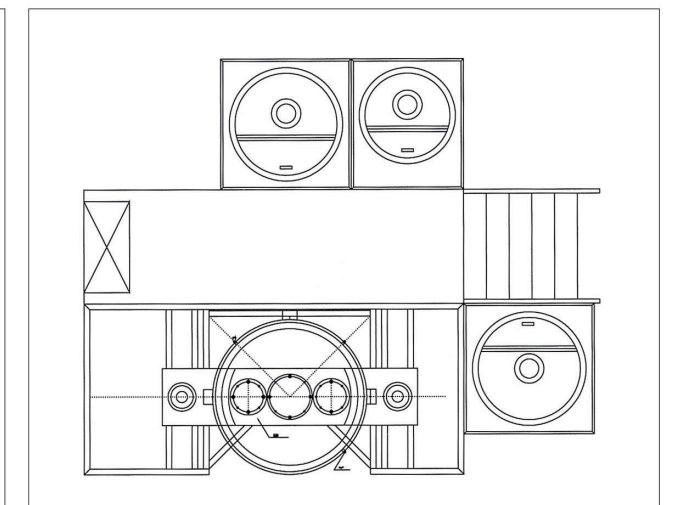
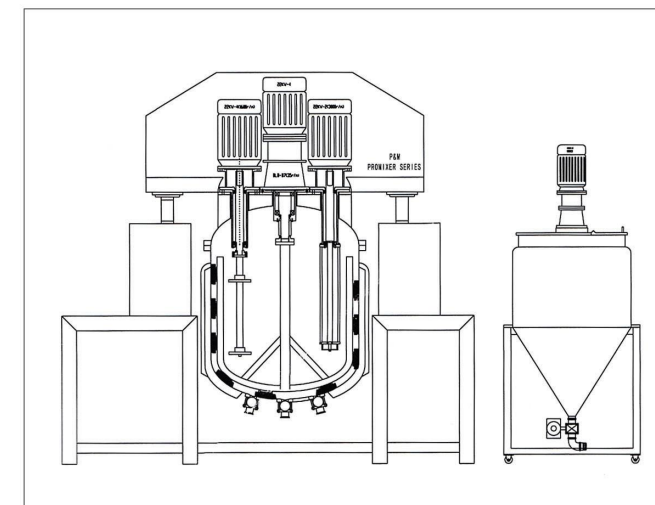
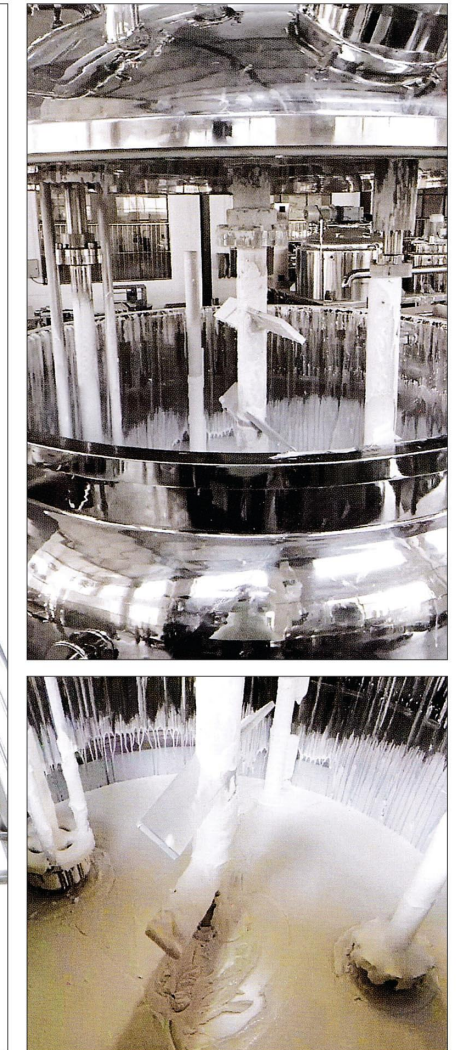

EMULSIFYING SERIES

| 乳化搅拌系列 |

乳化 Emulsifying

药乳液、药膏、雪花膏、面膜、面霜、乳化香精、油水乳化、乳化沥青、树脂化、蜡乳化、水性聚氨酯乳化、农药。



Medicine emulsion, ointment, vanishing cream, facial mask, face cream, emulsion flavor, oil-water emulsification, emulsified asphalt, resinification, wax emulsion, waterborne polyurethane emulsion, pesticide.

均质 Homogenizing

药乳液、药膏、雪花膏、面膜、面霜、组织匀浆、奶制品均质、果汁、打印墨水、果酱。

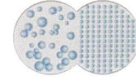

Medicine emulsion, ointment, vanishing cream, facial mask, face cream, tissue homogenate, dairy production emulsion, juice, ink, jam.

LIQUID WASHING MIXER PYG 洗液搅拌锅

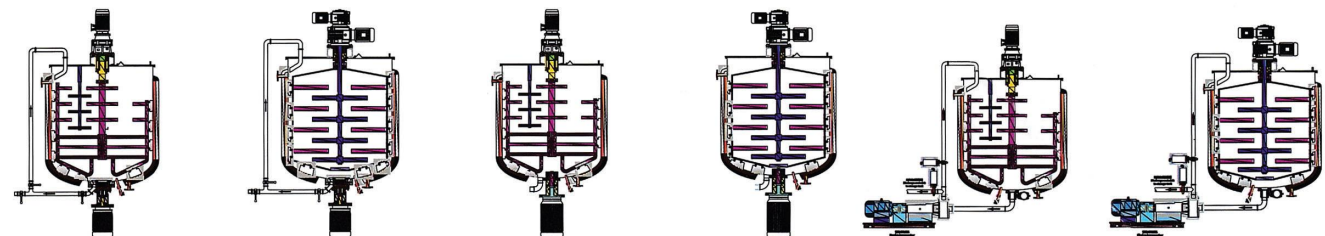

Single Way Mixing Internal & External Circulation
单搅拌内外循环

Double Way Mixing Internal & External Circulation
双搅拌内外循环

Single Way Mixing Internal & Circulation
单搅拌内循环

Double Way Mixing Internal & Circulation
双搅拌内循环

Single Way Mixing & External Homogenizer
单搅拌外置均质机

Double Way Mixing & External Homogenizer
双搅拌外置均质机

MIXING TANK PZG 搅拌罐



Multi Function Emulsify Tank
乳化罐



Lift emulsify Tank
可升降乳化罐



Mix Tank
搅拌罐



Magnetic Mix Tank
磁力搅拌罐



Movable Sealed Storage Tank
移动式密封储罐



Injection Tank
配液罐

EMULSIFYING SERIES

| 乳化搅拌系列 |

HIGH SHEARING HOMOGENIZER
YD 移动升降均质机



LAB EMULSIFY MACHINE
CB 实验室乳化机

